

Product Information

DIL/NetPC DNP/5370

Embedded Linux Module with Ethernet, CAN and VoIP Support



Description

The DIL/NetPC DNP/5370 provides a very compact Analog Devices BF537 32-bit Blackfin embedded controller with preinstalled U-Boot boot loader, Linux O/S, full-featured TCP/IP stack, Web (HTTP) server, Telnet and (T)FTP support for embedded networking applications with Ethernet connectivity.

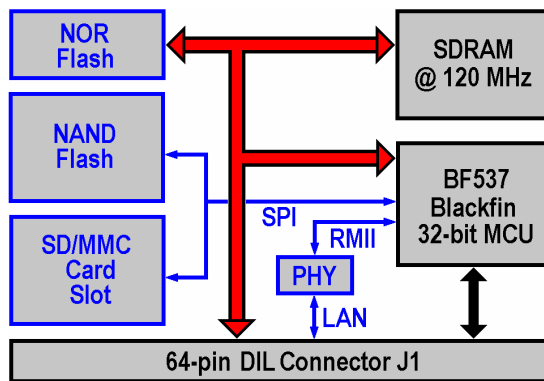

Block diagram DNP/5370: The DIL/NetPC DNP/5370 comes with a 10/100 Mbps Ethernet LAN interface, 20-bit GPIO, 1x SSI/I2S, 1x CAN, 1x TWI/I2C, 2x UART. The 8-bit bus interface (available over the DIL-64 connector) supports the connection to external chips and devices. The main application area of the DNP/5370 is the field of embedded networking gateways with VoIP support.

The DNP/5370 is built around the Analog Devices BF537 32-bit Blackfin microcontroller unit (MCU) running with 600 MHz. The external main components for the BF537 MCU are one NOR Flash memory chip with 3 MByte, one NAND Flash memory chip with 8 MByte, one 32 MByte SDRAM memory chip, one SD/MMC card slot and one PHY chip for the 10/100 Mbps Ethernet LAN interface.

The DNP/5370 offers the footprint of a standard 64-pin DIL socket with 2.54 mm centers and all the hardware and software features necessary to add high-speed Ethernet and device connectivity capabilities to any product design. The DNP/5370 is developed specifically for products that need to be connected to 10/100 Mbps Ethernet-based TCP/IP networks on one side and SSI/I2S, TWI/I2C, CAN and UARTs on the other side.

The DNP/5370 CAN 2.0b interface supports remote frames, data filtering on first two bytes and both the base (11-bit identifier) and extended (29-bit identifier) frame formats.

Technical Data DNP/5370

Basic

CPU	Analog Devices BF537 32-bit Blackfin MCU
Speed	600 MHz
RAM	32 MByte SDRAM @ 120 MHz bus speed
Flash	3 MByte NOR Flash memory for O/S boot image 8 MByte NAND Flash memory for O/S R/W access 1x SD/MMC card slot with preinstalled 128 MByte MMC
Ethernet	1x 10/100 Mbps Ethernet
Software	U-Boot 1.1.3 and µClinux 2.6.16 preinstalled

I/O Functions

Parallel I/Os	20-bit GPIO with PPI for ITU-R 656 support
Serial I/Os	2x UART (one with full handshakes) 1x SSI/I2S (Synchronous Serial Interface) 1x TWI (Two-wired Interface) with I2C support
CAN	1x CAN 2.0b interface
Bus Interface	8-bit for external I/O devices

Special Functions

RTC	1x Real Time Clock with external battery-backup
Watchdogs	1x timer watchdog, 1x power supervisor
Chip Select Outputs	2x CS output lines for external expansion
Interrupts	3x INT interrupt input line for external devices
LEDs	3x LED for LAN status and traffic

Other

Mechanical	64-pin DIL form factor
Size	29 mm x 82 mm
Power	3.3 VDC
Current	300 mA typical

Delivery

DNP/5370	DNP/5370 with preinstalled embedded Linux O/S
DNP/SK28	Starter Kit with DNP/5370 and evaluation board DNP/EVA13

SSV GmbH
Embedded Systems
Heisterbergallee 72
D-30453 Hannover

Phone: +49(0)511 / 40 000-45
Fax: +49(0)511 / 40 000-40
www.dilnetpc.com
kge@ist1.de