

# ***DIL/NetPC DNP/9200***

## *Board Revision 1.1*

# Hardware Reference

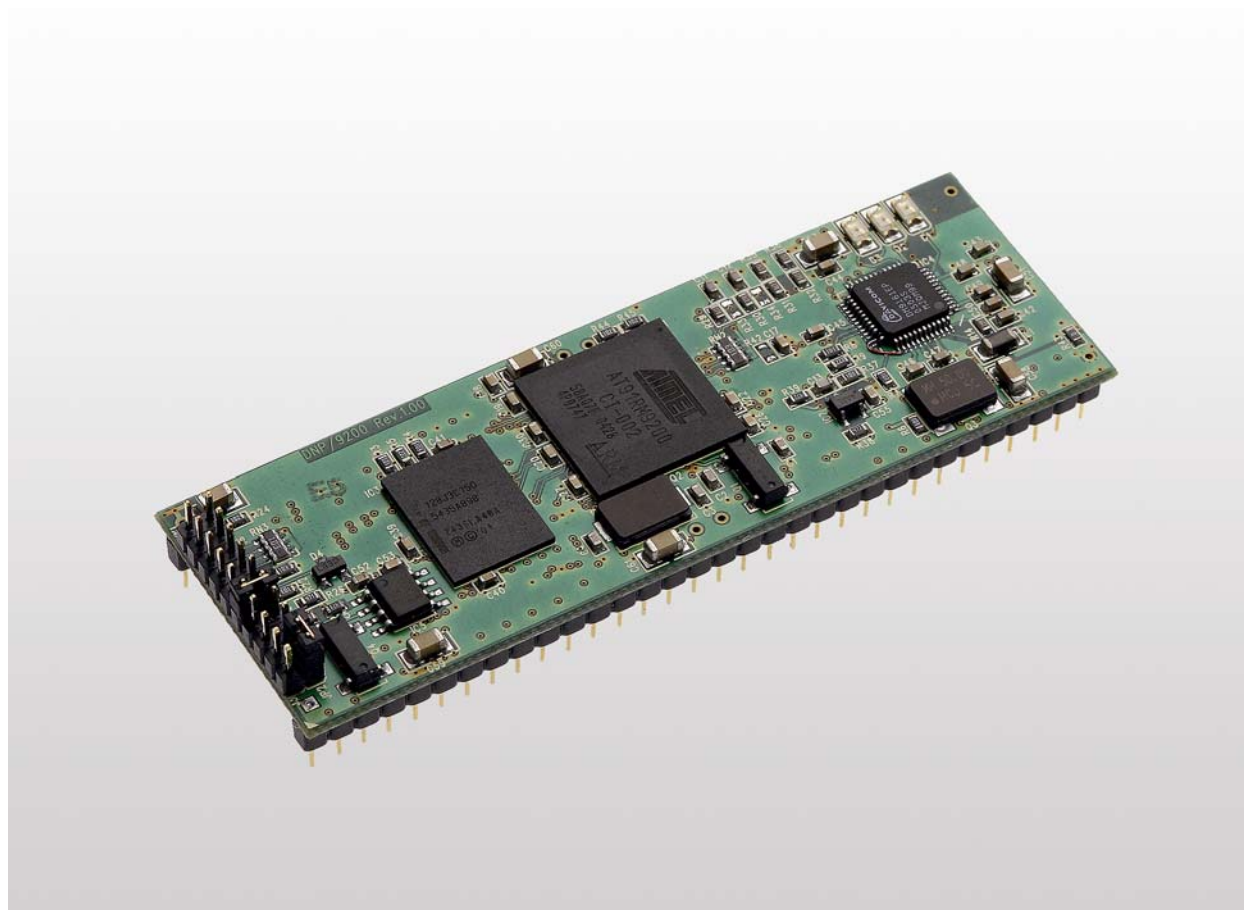

### **SSV Embedded Systems**

Heisterbergallee 72

D-30453 Hannover

Phone: +49-(0)511-40000-0

Fax: +49-(0)511-40000-40

E-mail: [sales@ist1.de](mailto:sales@ist1.de)

Manual Revision: 1.0

Date: 2005-12-06

## CONTENT

---

1	INTRODUCTION.....	3
1.1	Block Diagram.....	3
1.2	Features DNP/9200.....	4
2	BOARD LAYOUT.....	5
3	PINOOTS.....	6
3.1	DIL-64 Connector – J1 (1. Part).....	6
3.2	DIL-64 Connector – J1 (2. Part).....	7
3.3	JTAG Connector – J2.....	8
3.4	JTAG Interface.....	9
3.5	RCM Jumper – JP1.....	10
3.6	Boot Mode Select Jumper – JP2.....	11
4	MECHANICAL DIMENSIONS.....	12
	CONTACT.....	13
	DOCUMENT HISTORY.....	13

# 1 INTRODUCTION

This document describes the hardware components of the DNP/9200. For further information about the individual components of this product you may follow the links from our website at <http://www.dilnetpc.com>. Our website contains a lot of technical information, which will be updated in regular periods.

The DIL/NetPC DNP/9200 provides a very compact Atmel AT91RM9200 ARM9-based embedded controller with preinstalled U-Boot boot loader, Linux O/S, full-featured TCP/IP stack, Web (HTTP) server, Telnet and (T)FTP support, USB Host and Device port for embedded networking applications with Ethernet and USB connectivity.

## 1.1 Block Diagram

The DIL/NetPC DNP/9200 comes with a 10/100 Ethernet LAN interface, 20-bit GPIO, 1 x SPI, 2 x UARTs, 1 x USB Host port and 1 x USB Device port. The 8-bit bus interface (available over the DIL-64 connector) supports the connection to external chips and devices. The main application area of the DNP/9200 is the field of Ethernet-to-USB gateways for modern industrial and laboratory environments. Figure 1 shows the block diagram of this small 32-bit embedded Linux computer.

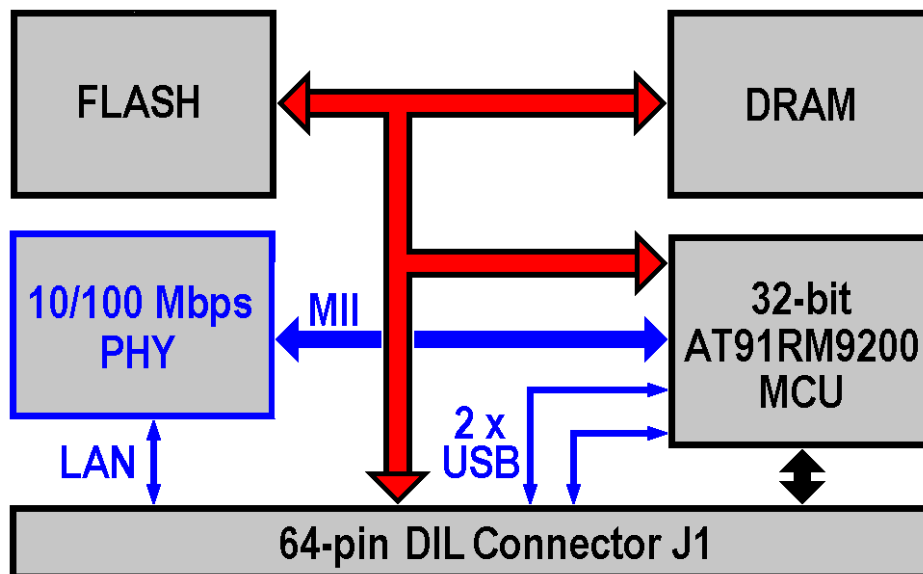

Figure 1: Block diagram of DNP/9200

---

## 1.2 Features DNP/9200

---

- Atmel AT91RM9200 32-bit ARM9 MCU with 180 MHz clock speed
- 200 MIPS @ 180 MHz
- 32 Mbyte 32-bit SDRAM memory
- 16 Mbyte FLASH memory
- 10/100 Mbps Ethernet interface
- One USB host port (full-speed and low-speed)
- One USB device port (full-speed and low-speed)
- One serial peripheral interface (SPI)
- Two serial ports (one with all handshakes)
- 20-bit general purpose high-speed parallel I/O
- 8-bit I/O expansion bus
- One interrupt input, 4 chip select outputs
- Programmable watchdog timer
- JTAG IEEE 1149.1 test interface
- In-system programming features
- 64-pin JEDEC DIL-64 connector, 2.54 mm centers
- 3.3 Volt low power design, supply voltage 3.3 VDC ( $\pm 5\%$ )
- Supply current 300 mA typ. @ 180 MHz
- 0 °C to +70 °C operating temperature
- Size 82 mm x 28 mm

## 2 BOARD LAYOUT

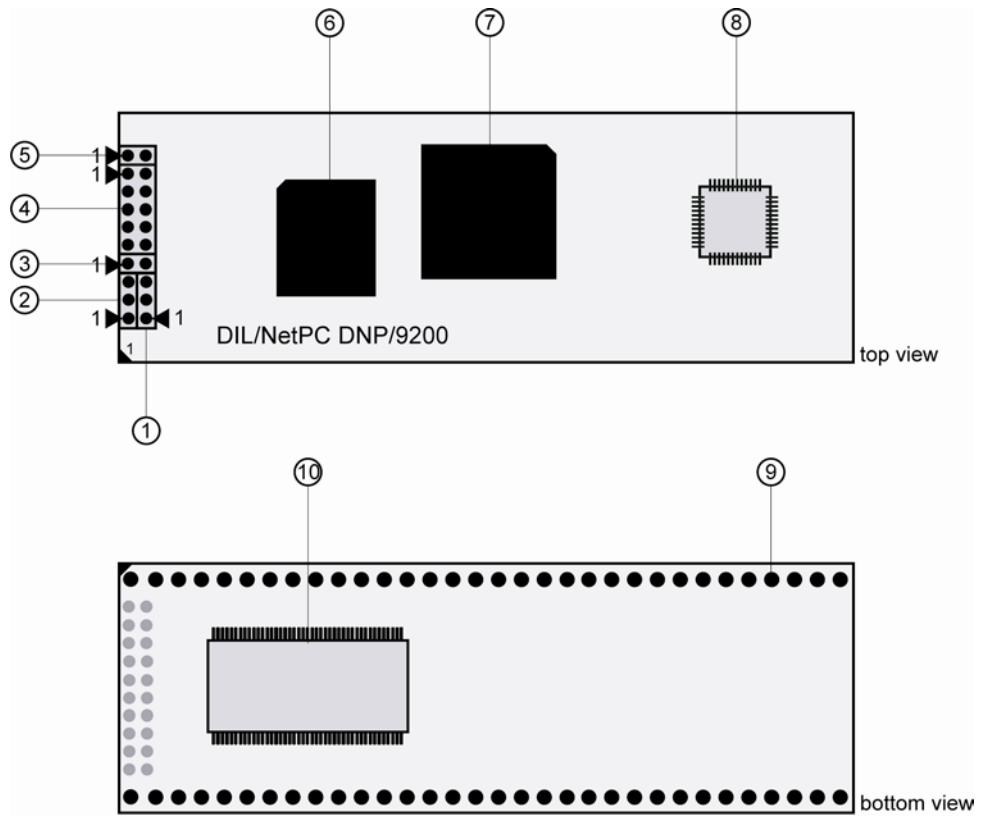

- |                                |                                   |
|--------------------------------|-----------------------------------|
| ① JP2 - Boot mode select       | ⑥ Flash memory                    |
| ② J3 - Serial debug port       | ⑦ Atmel AT91RM9200 CPU            |
| ③ JP3 - JTAG select            | ⑧ 10/100 Mbps Ethernet controller |
| ④ J2 - CPU-JTAG / Service port | ⑨ J1 - 64-pin DIL socket          |
| ⑤ JP1 - RCM jumper             | ⑩ SDRAM                           |

Figure 2: Board layout DNP/9200

## 3 PINOUTS

### 3.1 DIL-64 Connector – J1 (1. Part)

Pin	Name	Group	Function
1	PA0	PIO	Parallel I/O, Port A, Bit 0 (see also: Alternate Function)
2	PA1	PIO	Parallel I/O, Port A, Bit 1 (see also: Alternate Function)
3	PA2	PIO	Parallel I/O, Port A, Bit 2 (see also: Alternate Function)
4	PA3	PIO	Parallel I/O, Port A, Bit 3 (see also: Alternate Function)
5	PA4	PIO	Parallel I/O, Port A, Bit 4 (see also: Alternate Function)
6	PA5	PIO	Parallel I/O, Port A, Bit 5 (see also: Alternate Function)
7	PA6	PIO	Parallel I/O, Port A, Bit 6
8	PA7	PIO	Parallel I/O, Port A, Bit 7
9	PB0	PIO	Parallel I/O, Port B, Bit 0 (see also: Alternate Function)
10	PB1	PIO	Parallel I/O, Port B, Bit 1 (see also: Alternate Function)
11	PB2	PIO	Parallel I/O, Port B, Bit 2 (see also: Alternate Function)
12	PB3	PIO	Parallel I/O, Port B, Bit 3 (see also: Alternate Function)
13	PB4	PIO	Parallel I/O, Port B, Bit 4 (see also: Alternate Function)
14	PB5	PIO	Parallel I/O, Port B, Bit 5 (see also: Alternate Function)
15	PB6	PIO	Parallel I/O, Port B, Bit 6 (see also: Alternate Function)
16	PB7	PIO	Parallel I/O, Port B, Bit 7 (see also: Alternate Function)
17	PC0	PIO	Parallel I/O, Port C, Bit 0 (see also: Alternate Function)
18	PC1	PIO	Parallel I/O, Port C, Bit 1 (see also: Alternate Function)
19	PC2	PIO	Parallel I/O, Port C, Bit 2 (see also: Alternate Function)
20	PC3	PIO	Parallel I/O, Port C, Bit 3 (see also: Alternate Function)
21	RXD1	SIO	COM1 Serial Port, RXD Pin
22	TXD1	SIO	COM1 Serial Port, TXD Pin
23	CTS1	SIO	COM1 Serial Port, CTS Pin
24	RTS1	SIO	COM1 Serial Port, RTS Pin
25	DCD1	SIO	COM1 Serial Port, DCD Pin
26	DSR1	SIO	COM1 Serial Port, DSR Pin
27	DTR1	SIO	COM1 Serial Port, DTR Pin
28	RI1	SIO	COM1 Serial Port, RI Pin
29	RESIN	RESET	RESET Input
30	TX+	LAN	10BASE-T/100BASE-TX Ethernet Interface, TX+ Pin
31	TX-	LAN	10BASE-T/100BASE-TX Ethernet Interface, TX- Pin
32	GND	---	Ground

Table 1: Pinout DIL-64 connector – pin 1 to 32

## 3.2 DIL-64 Connector – J1 (2. Part)

Pin	Name	Group	Function
33	RX+	LAN	10BASE-T/100BASE-TX Ethernet Interface, RX+ Pin
34	RX-	LAN	10BASE-T/100BASE-TX Ethernet Interface, RX- Pin
35	RESOUT	RESET	RESET Output
36	VBAT	PSP*	Real Time Clock Battery Input
37	CLKOUT	PSP*	Clock Output
38	TXD2	PSP*	COM2 Serial Port, TXD Pin
39	RXD2	PSP*	COM2 Serial Port, RXD Pin
40	HDMA	PSP*	USB Host Port- (Interrupt Input on other DIL/NetPCs)
41	HDP+	PSP*	USB Host Port+ (Interrupt Input on other DIL/NetPCs)
42	DDM	PSP*	USB Device Port- (Interrupt Input on other DIL/NetPCs)
43	DDP	PSP*	USB Device Port+ (Interrupt Input on other DIL/NetPCs)
44	INT1	PSP*	Interrupt Input 1
45	CS4	PSP*	Chip Select Output 4. Physical Address Range 0x7000.0000-0x7FFF.FFFF
46	CS3	PSP*	Chip Select Output 3. Physical Address Range 0x6000.0000-0x6FFF.FFFF
47	CS2	PSP*	Chip Select Output 2. Physical Address Range 0x5000.0000-0x5FFF.FFFF
48	CS1	PSP*	Chip Select Output 1. Physical Address Range 0x4000.0000-0x4FFF.FFFF
49	RDY	PSP*	External Ready Input
50	RD	PSP*	Read Signal, Expansion Bus
51	WR	PSP*	Write Signal, Expansion Bus
52	SA3	PSP*	Expansion Bus, Address Bit 3
53	SA2	PSP*	Expansion Bus, Address Bit 2
54	SA1	PSP*	Expansion Bus, Address Bit 1
55	SA0	PSP*	Expansion Bus, Address Bit 0
56	SD7	PSP*	Expansion Bus, Data Bit 7
57	SD6	PSP*	Expansion Bus, Data Bit 6
58	SD5	PSP*	Expansion Bus, Data Bit 5
59	SD4	PSP*	Expansion Bus, Data Bit 4
60	SD3	PSP*	Expansion Bus, Data Bit 3
61	SD2	PSP*	Expansion Bus, Data Bit 2
62	SD1	PSP*	Expansion Bus, Data Bit 1
63	SD0	PSP*	Expansion Bus, Data Bit 0
64	VCC	---	3.3 Volt Power Input

**Table 2: Pinout DIL-64 connector – pin 33 to 64**

\* **Please note:** Some pins are called "Product Specific Pins (PSP)". Other members of the *DIL/NetPC* family will differ with these pins from the *DNP/9200*. All other pins will have the same primary functions. The *DNP/9200* alternate functions (pin 1 to 20) are AT91RM9200-specific.

### 3.3 JTAG Connector – J2

You can use an adapter to convert the miniature 2 mm JTAG connector of the DNP/9200 to the common 2.54 mm raster. Then standard JTAG connector modules can be used.

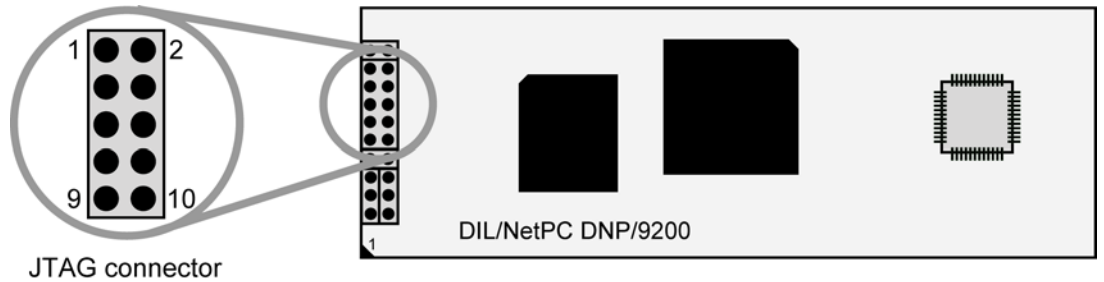

Figure 3: Position of JTAG connector on the DNP/9200

Pin	Name	Function
1	TDI	Test Data In
2	TDO	Test Data Out
3	TMS#	Test Mode Select
4	GND	Ground
5	TRST#	Test Reset
6	TCK	Test Clock
7	VCC	Power (3.3 VDC I/O Voltage)
8	RESET#	Reset
9	WDDIS#	Watchdog Disable
10	GND	Ground

Table 3: Pinout JTAG connector



### 3.4 JTAG Interface

The JTAG signals of the DNP/9200 connector J2 are directly connected to the JTAG TAP controller of the NS9200 32-bit ARM-MCU.

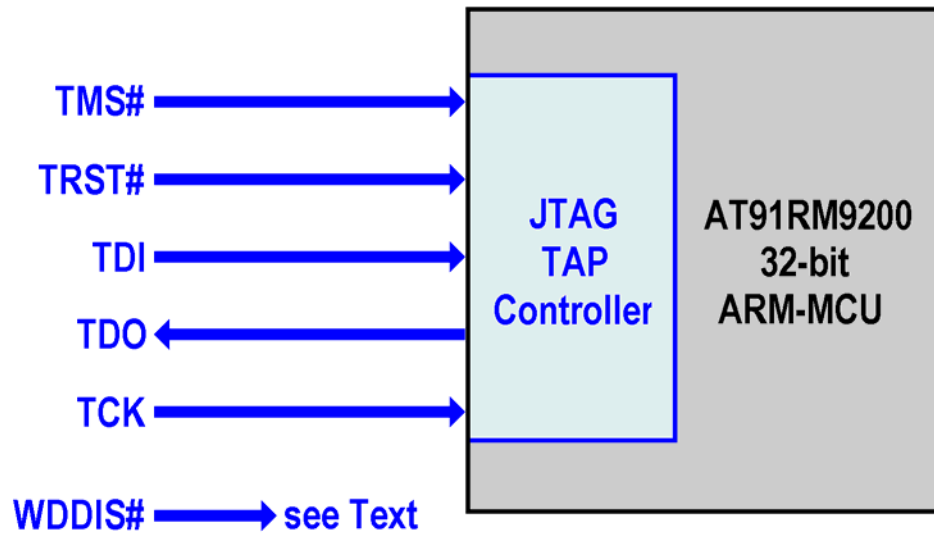

**Figure 4: DNP/9200 JTAG interface**

The WDDIS# input disables the on-board watchdog. This is necessary to access the 16 Mbytes Flash chip over JTAG programming tools.

### 3.5 RCM Jumper – JP1

The DIL/NetPC DNP/9200 boot sequence with **RCM enabled** is similar to the boot procedure with RCM disabled. Only the first step is different:

1. The DNP/9200 runs the U-Boot boot loader program. This software shows a wait message over the DNP/9200 COM1 serial interface if RCM is enabled. It is possible to interrupt the boot process and switch to the U-Boot command line interface. Just hit a key of your terminal emulation program.
2. Without interruption the U-Boot boot loader starts a Linux OS image after the wait period from the DNP/9200 Flash memory.

This is the DNP/9200 boot sequence with **RCM disabled**:

1. Direct after power-up, the DNP/9200 runs the U-Boot boot loader program for some milliseconds. U-Boot initializes the hardware components (hardware init). With RCM disabled there is no U-Boot text message output over the DNP/9200 COM1 serial interface and no boot delay-based wait period. After the hardware init, the U-Boot boot loader starts the Linux OS image.
2. Linux takes control over the DNP/9200 hardware and runs all necessary processes for coming up to live.

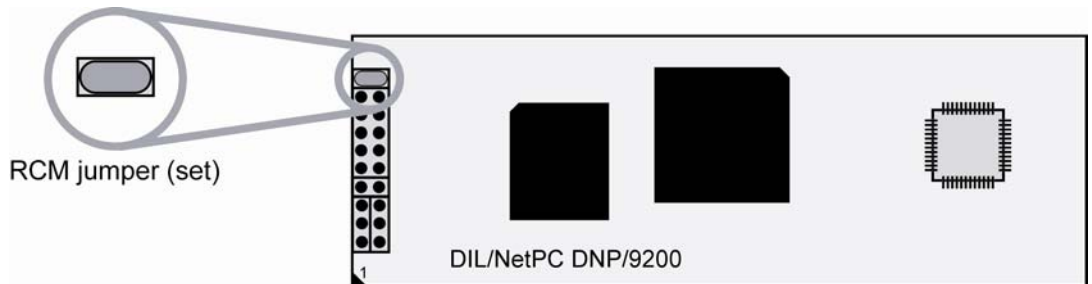

**Figure 5: Position of RCM jumper on the DNP/9200**

RCM jumper	Function
Set (default)	U-Boot shows wait message over the DNP/9200 COM1 serial interface
Not set	U-Boot initializes hardware components without wait message

**Table 4: RCM jumper settings**

### 3.6 Boot Mode Select Jumper – JP2

The boot mode select jumper shown in figure 6 is always necessary to enable the boot process from the on-board 16 Mbytes Flash memory chip.

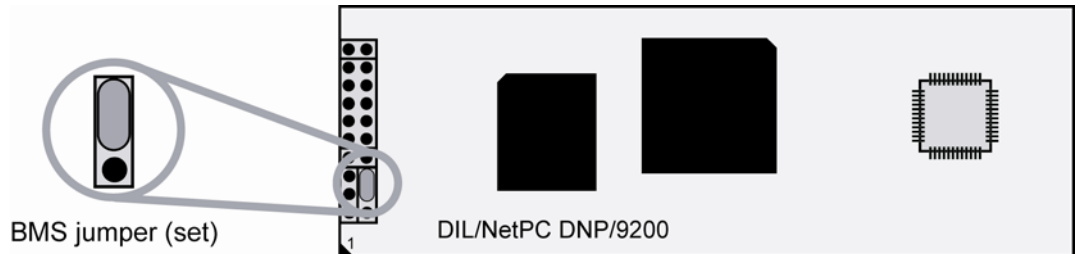

**Figure 6: Position of boot mode select jumper on the DNP/9200**

BMS jumper	Function
Set (default)	U-Boot boots from DNP/9200 Flash memory chip
Not set	Undefined

**Table 5: Boot mode select jumper settings**

## 4 MECHANICAL DIMENSIONS

All length dimensions have a tolerance of 0.5 mm.

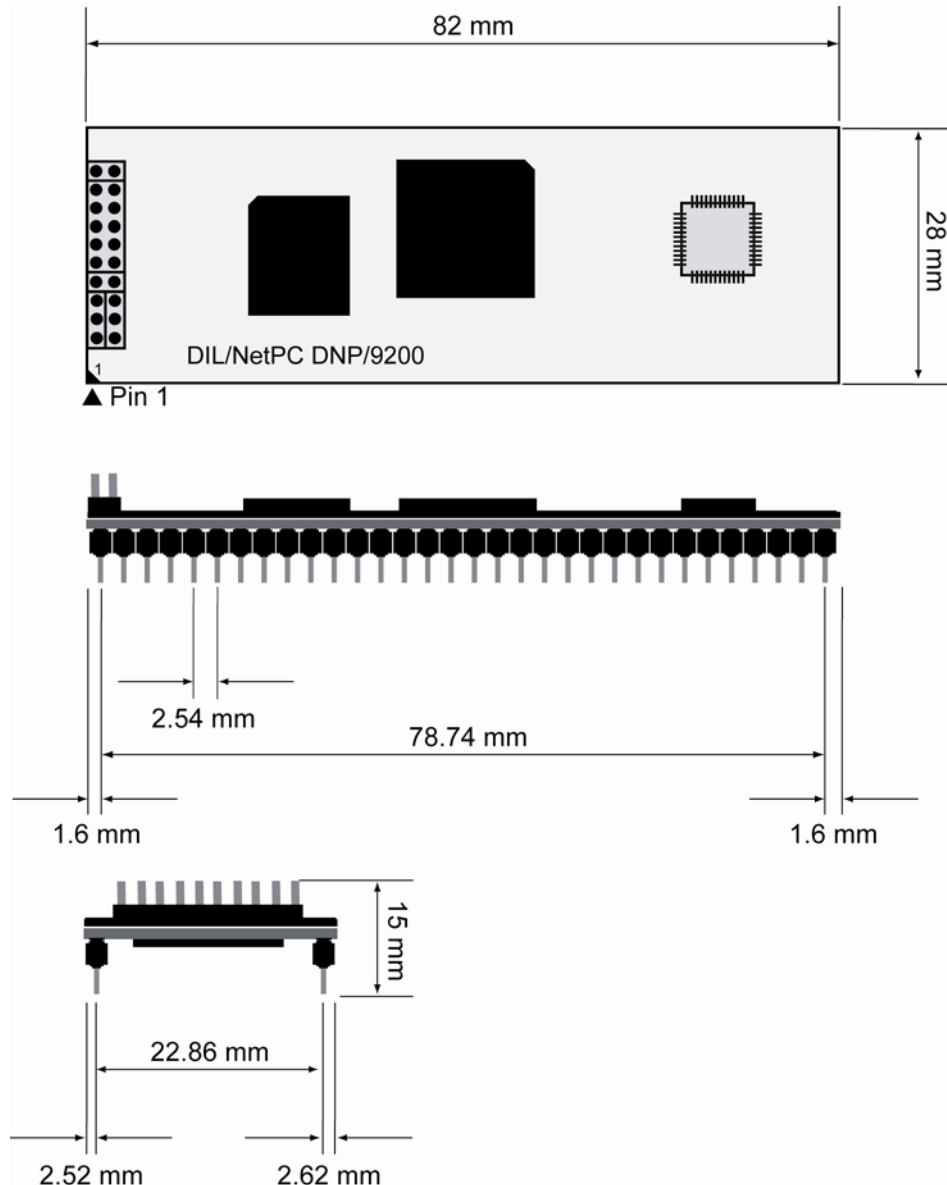

Figure 7: Mechanical dimensions of DNP/9200

## CONTACT

---

**SSV Embedded Systems**  
Heisterbergallee 72  
D-30453 Hannover / Germany  
Phone: +49-(0)511-40000-0  
Fax: +49-(0)511-40000-40  
E-mail: sales@ist1.de  
Internet: www.dilnetpc.com

## DOCUMENT HISTORY

---

Revision	Date	Remarks	Name
1.0	2005-12-06	first version	WBU

The content of this document can change any time without announcement. There is taken over no guarantee for the accuracy of the statements. The user assumes the entire risk as to the accuracy and the use of this document. Information in this document is provided 'as is' without warranty of any kind. Some names within this document can be trademarks of their respective holders.

© 2005 SSV EMBEDDED SYSTEMS. All rights reserved.