

## PNP/5280 $\mu$ Clinux Starter Kit: First Steps

The DIL/NetPC PNP/5280 embedded Linux starter kits DNP/SK20 contains everything you need to get started with your Motorola MCF5280 ColdFire-based embedded networking application. The starter kits includes a PNP/5280 module with a pre-installed embedded Linux (uClinux), the evaluation board DNP/EVA8, power supply, serial interface (null modem) cable, a CD-ROM with software and documentation and a printed user manual for the first steps with the starter kit.

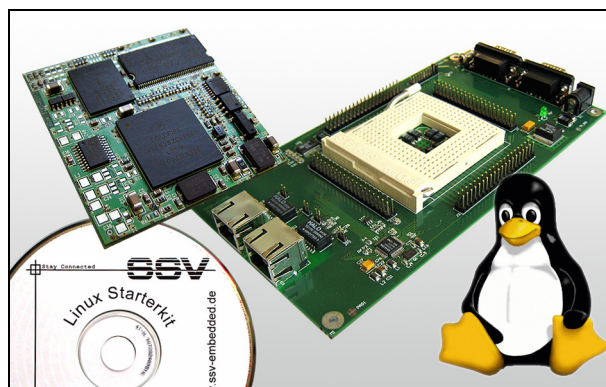

**Figure 1:** The DIL/NetPC PNP/5280  $\mu$ Clinux Starter Kit DNP/SK20

The starter kit CD-ROM comes with a full GNU cross tool chain for C/C++ software development. This binary files of this tool chain runs on a x86 Linux-based host (SuSE, Red Hat or other) and builds *bFLT* (uClinux Binary Flat Format) binary files for the Motorola MCF5280 ColdFire 32-bit RISC microcontroller.

For using the DIL/NetPC PNP/5280 Embedded Linux Starter Kit you need a development system. The minimal configuration for this system is a Windows-based PC with the HyperTerminal terminal emulation program and a free COM port (COM1, COM2 or USB-based COMx) for the RS232 serial link between the DIL/NetPC PNP/5280 and HyperTerminal.

For using the Ethernet link, your PC needs an Ethernet adapter with 10 Mbps or 10/100 Mbps LAN interface. This environment allows web server programming (HTML pages, Java Applets) and Linux shell script programming. For using the GNU C/C++ cross tool chain, it is necessary to run Linux on the development system.\*

\* Alternatively the SSV coLinux Environment with the pre-build tool chain for Windows XP-based PCs can be used instead of Linux.

## The PNP/5280 Embedded Linux Starter Kit Key Features

---

The DIL/NetPC PNP/5280 pre-installed embedded Linux consists of two main components: 1. the Linux kernel and 2. the root file system. The PNP/5280 Flash also offers a Flash Loader for downloading new versions of the Linux kernel and the root file system. This in-system programming feature can be used by a simple serial and Ethernet link between the development system and the PNP/5280.

- DIL/NetPC PNP/5280 with 6 MHz Motorola MCF5280 ColdFire and Firmware in Flash memory, 3.3 VDC Vcc
- Firmware and Embedded Linux pre-installed in Flash memory
- SK20: Evaluation Board DNP/EVA8
- Null modem Cable
- 110 VAC or 230 VAC to 5 VDC International Power Supply
- CD-ROM with User Manual and Hardware/Programmers Manuals
- Embedded Linux with Source
- GNU Cross Tool Chain for C/C++ Software Development for Linux-based PCs
- *elf2flt* Converter Program (m68k ELF to uClinux bFLT)
- GNU *gdb* and *gdbserver* for Ethernet-based Remote Debugging
- Free TFTP Server Program for Win32-based PCs
- Free DHCP Server Program for Win32-based PCs
- Linux Remote Login with Telnet
- Web Server Setup Sample
- Embedded TFTP Client
- Many Sourcecode Samples

## 1. Step: Cable for the Serial Link between the PNP/5280 and a PC

Set-up the serial link between the DIL/NetPC PNP/5280 Evaluation Board and your PC. Use a null modem cable for this connection.

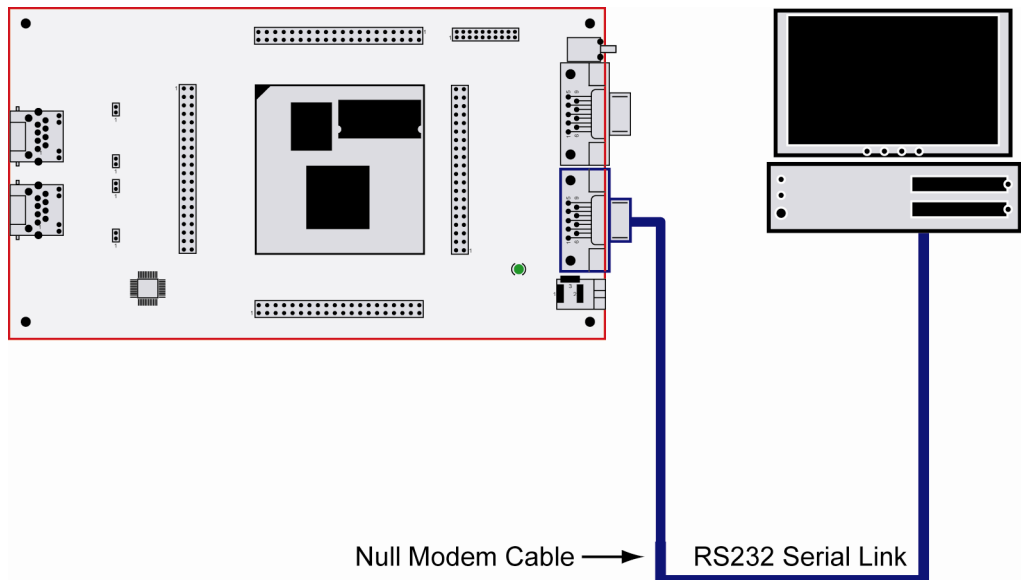
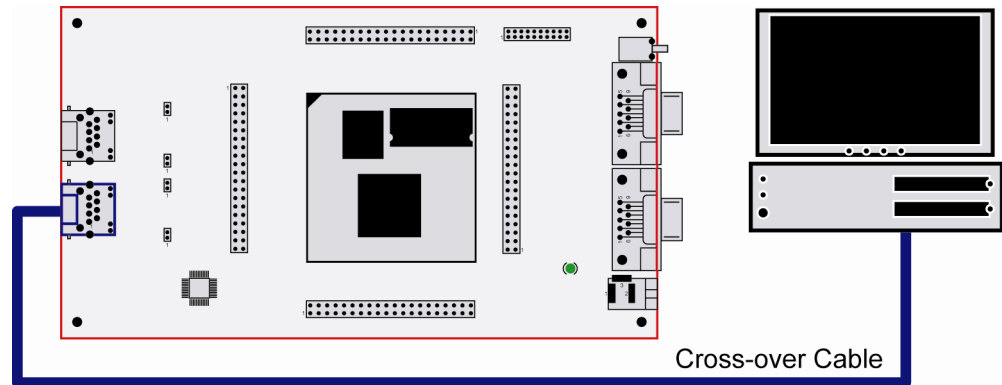

**Figure 2:** Serial Link between the DIL/NetPC Evaluation Board and the PC

Connect one end of the null modem cable with the COM1 port of the Evaluation Board and the other end with an unused COM port of your PC. Make sure, that this PC COM port supports 115.200 bps.

## 2. Step: Cable for the Ethernet Link between the PNP/5280 and a PC

Set-up the Ethernet LAN link between the LAN1 connector of the DIL/NetPC PNP/5280 Evaluation Board and your PC. Use an Ethernet Cross-over cable for the first LAN connection.

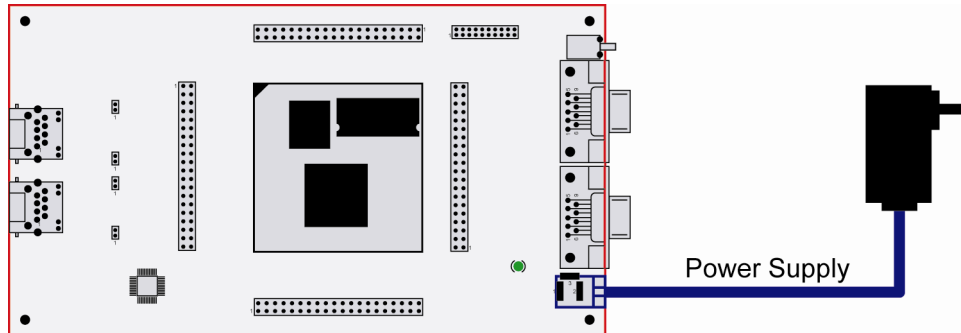

**Figure 3:** Ethernet Link between the DIL/NetPC Evaluation Board and the PC

**Please note:** The PNP/5280 comes with a default IP address of 192.168.0.126. Please make sure that your PC can work with the IP address range 192.168.0.x.

### 3. Step: Connect the Power Supply and Power-up the Starter Kit

Connect a 5 VDC power supply to DIL/NetPC PNP/5280 Evaluation Board. Make sure, that the + voltage is within the center of the power supply connector (please see **fig. 4a**).



**Figure 4:** Power Supply for the DIL/NetPC Evaluation Board

**Please note:** Make sure, that all cable connections are OK. Before pwer up please run your terminla emulation program with the right set-up (see next step for more details).

Polarity:



**Figure 4a:** Polarity of the power supply connector

## 4. Step: Using the Serial Link with a Terminal Program

Run *HyperTerminal* on your Windows-PC, *minicom* or a similar simple terminal emulation program on your Linux-based PC.



**Figure 5:** Direct Connection Set-up with *HyperTerminal*

Set-up a direct connection with the parameters of Table 1. Make sure, that the PC COM port supports 115.200 bps.

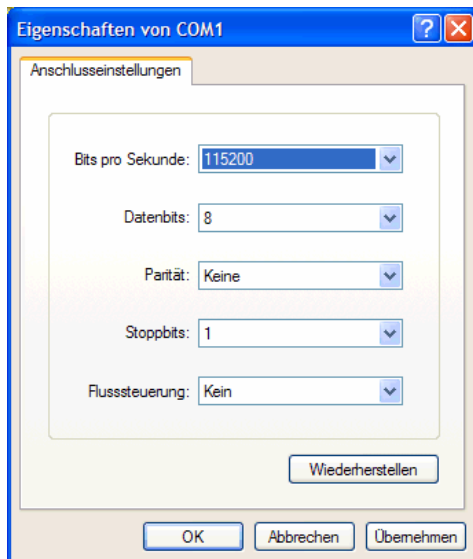

**Figure 6:** Parameter Set-up with *HyperTerminal*

Parameter	Value
Speed	115.200 bps
Data Bits	8
Parity	None
Stop Bits	1
Protocol	No (Xon/Xoff, RTS/CTS or similar)

**Table 1:** Set-up Parameters for the Serial Link

## 5. Step: Power-up the PNP/5280 without RCM Jumper

Without the RCM jumper, the DIL/NetPC PNP/5280 is booting  $\mu$ Clinux from Flash memory within some seconds.

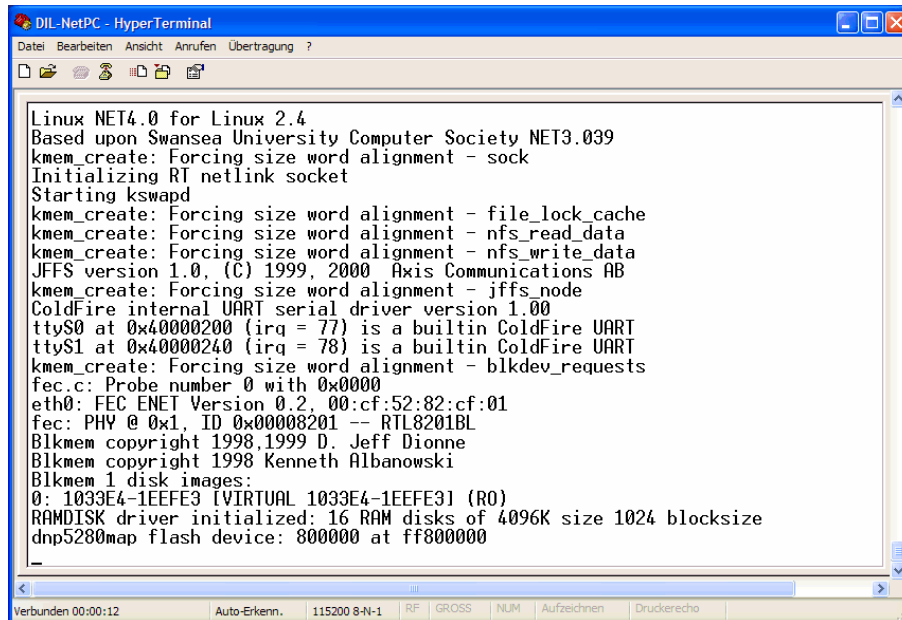

```
DIL-NetPC - HyperTerminal
Datei Bearbeiten Ansicht Anrufen Übertragung ?
Linux NET4.0 for Linux 2.4
Based upon Swansea University Computer Society NET3.039
kmem_create: Forcing size word alignment - sock
Initializing RT netlink socket
Starting kswapd
kmem_create: Forcing size word alignment - file_lock_cache
kmem_create: Forcing size word alignment - nfs_read_data
kmem_create: Forcing size word alignment - nfs_write_data
JFFS version 1.0, (C) 1999, 2000 Axis Communications AB
kmem_create: Forcing size word alignment - jffs_node
ColdFire internal UART serial driver version 1.00
ttyS0 at 0x40000200 (irq = 77) is a builtin ColdFire UART
ttyS1 at 0x40000240 (irq = 78) is a builtin ColdFire UART
kmem_create: Forcing size word alignment - blkdev_requests
fec.c: Probe number 0 with 0x0000
eth0: FEC ENET Version 0.2, 00:cf:52:82:cf:01
fec: PHY @ 0x1, ID 0x00008201 -- RTL8201BL
Blkmem copyright 1998,1999 D. Jeff Dionne
Blkmem copyright 1998 Kenneth Albanowski
Blkmem 1 disk images:
0: 1033E4-1EEFE3 [VIRTUAL 1033E4-1EEFE3] (RO)
RAMDISK driver initialized: 16 RAM disks of 4096K size 1024 blocksize
dnp5280map flash device: 800000 at ff800000
_
```

**Figure 7:** Watch the  $\mu$ Clinux booting process with *HyperTerminal*

The terminal emulation program offers a serial console to the PNP/5280  $\mu$ Clinux. You can enter and execute  $\mu$ Clinux commands with the terminal emulation program.

## 6. Step: Power-up the PNP/5280 with RCM Jumper

With the RCM jumper, the DIL/NetPC PNP/5280 runs the default boot loader and ROM monitor program *dBUG* direct after power-up from Flash memory.

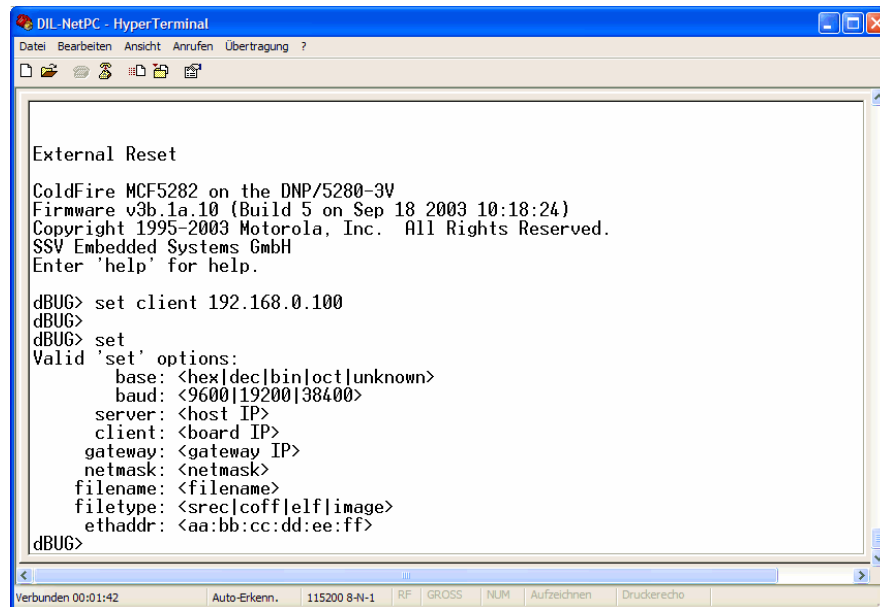

```
DIL-NetPC - HyperTerminal
Datei Bearbeiten Ansicht Anrufen Übertragung ?
[Icons]

External Reset
ColdFire MCF5282 on the DNP/5280-3V
Firmware v3b.1a.10 (Build 5 on Sep 18 2003 10:18:24)
Copyright 1995-2003 Motorola, Inc. All Rights Reserved.
SSV Embedded Systems GmbH
Enter 'help' for help.

dBUG> set client 192.168.0.100
dBUG>
dBUG> set
Valid 'set' options:
  base: <hex|dec|bin|oct|unknown>
  baud: <9600|19200|38400>
  server: <host IP>
  client: <board IP>
  gateway: <gateway IP>
  netmask: <netmask>
  filename: <filename>
  filetype: <srec|coff|elf|image>
  ethaddr: <aa:bb:cc:dd:ee:ff>
dBUG>
```

**Figure 8:** Using *dBUG* with *HyperTerminal*

The monitor program *dBUG* allows you to change the IP address of the PNP/5280. Please enter the following command:

```
set client 192.168.0.100
```

This command changes the IP address of the PNP/5280 to 192.168.0.100 and stores the address to the Flash memory chip. Please enter

```
help
```

for an overview of all *dBUG* commands. See also the *Motorola dBUG Reference Manual* for more details.



## 7. Step: Check the IP Address of your PC

---

Make sure that your PC is using the right IP address for the Ethernet-based TCP/IP communication with the DIL/NetPC. Use 192.168.0.1 or 192.168.0.254 for your PC and 192.168.0.126 for the PNP/5280.



```
Eingabeaufforderung
Microsoft Windows XP [Version 5.1.2600]
(C) Copyright 1985-2001 Microsoft Corp.
C:\Dokumente und Einstellungen\kdw>ipconfig
Windows-IP-Konfiguration

Ethernetadapter LAN-Verbindung:

    Verbindungsspezifisches DNS-Suffix:
    IP-Adresse. . . . . : 192.168.0.254
    Subnetzmaske. . . . . : 255.255.255.0
    Standardgateway . . . . . :

C:\Dokumente und Einstellungen\kdw>
```

**Figure 9:** Windows-PC IP address check with *ipconfig*

Talk to your network administrator if you have problems with the IP address understanding.

## 8. Step: Check the Ethernet-based TCP/IP Communication

---

Check the Ethernet-based TCP/IP communication between the PNP/5280 and the PC with a simple *ping* command.

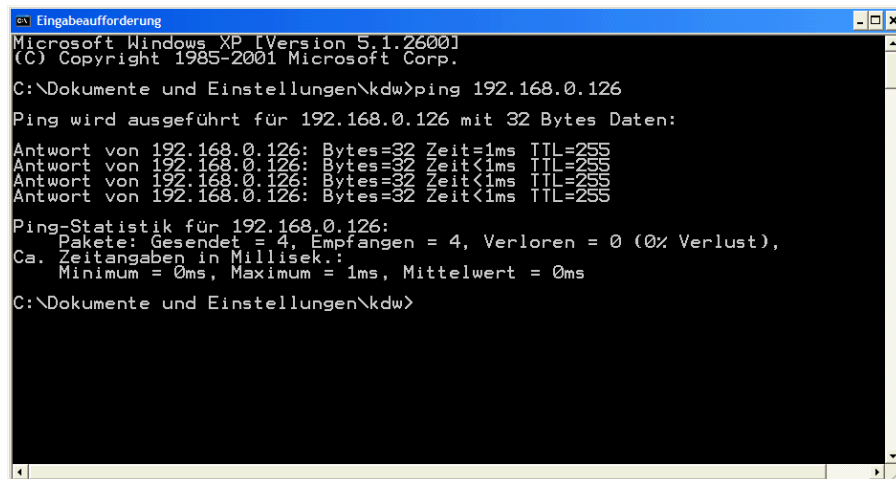

```
Eingabeaufforderung
Microsoft Windows XP [Version 5.1.2600]
(C) Copyright 1985-2001 Microsoft Corp.
C:\Dokumente und Einstellungen\kdw>ping 192.168.0.126
Ping wird ausgeführt für 192.168.0.126 mit 32 Bytes Daten:
Antwort von 192.168.0.126: Bytes=32 Zeit=1ms TTL=255
Antwort von 192.168.0.126: Bytes=32 Zeit<1ms TTL=255
Antwort von 192.168.0.126: Bytes=32 Zeit<1ms TTL=255
Antwort von 192.168.0.126: Bytes=32 Zeit<1ms TTL=255
Ping-Statistik für 192.168.0.126:
    Pakete: Gesendet = 4, Empfangen = 4, Verloren = 0 (0% Verlust),
    Ca. Zeitangaben in Millisek.:
        Minimum = 0ms, Maximum = 1ms, Mittelwert = 0ms
C:\Dokumente und Einstellungen\kdw>
```

**Figure 10:** Windows-PC TCP/IP communication check with *ping*

First check the cable connections and then the IP addresses if your *ping* doesn't work.

## 9. Step: Check the PNP/5280 Embedded Web server

Run a Web browser program. Enter the URL `http://192.168.0.126` for access the PNP/5280 Web pages.

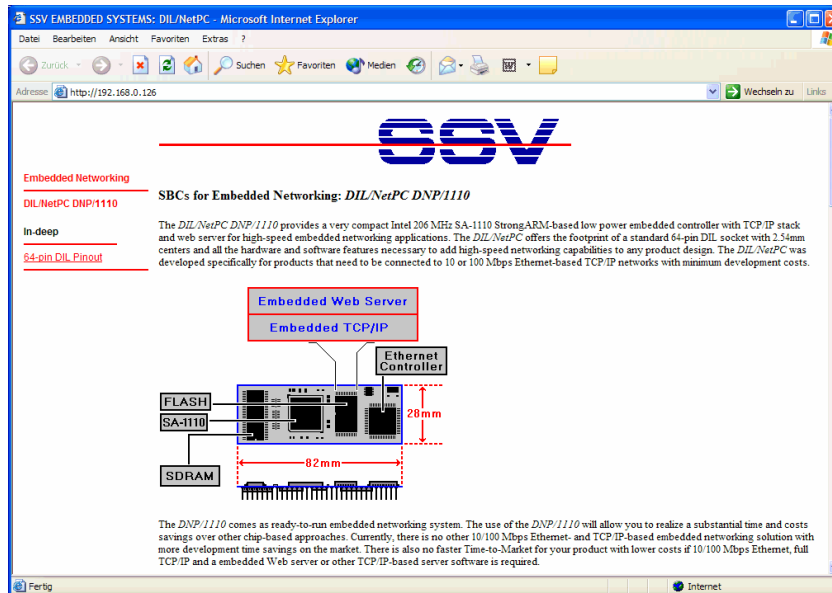
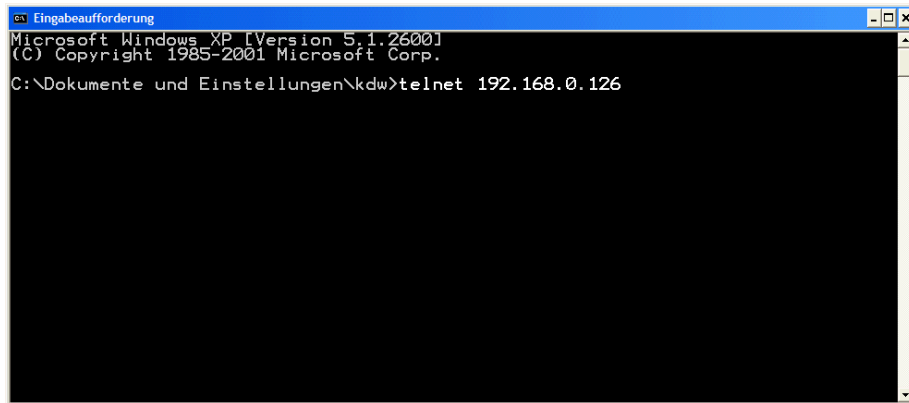

**Figure 11:** Check the Embedded Webserver with *Internet Explorer*

**Please note:** The PNP/5280 default HTML pages and GIF pictures are located at `/home/httpd` in the PNP/5280 Flash memory.

## 10. Step: Using a Telnet Connection

Run a Telnet client program on your PC with the IP address of the PNP/5280. You can use a Telnet session for remote entering  $\mu$ Clinux commands.



**Figure 12:** Run the Windows telnet client program

**Please note:** The PNP/5280  $\mu$ Clinux comes with *BusyBox*. All  $\mu$ Clinux command lines commands are implemented in *BusyBox*. *BusyBox* combines tiny versions of many common UNIX utilities into a single small executable. It provides replacements for most of the utilities you usually find in GNU *fileutils*, *shellutils*, etc. The utilities in *BusyBox* generally have fewer options than their full-featured GNU cousins; however, the options that are included provide the expected functionality and behave very much like their GNU counterparts. *BusyBox* provides a fairly complete environment for any small or embedded system.

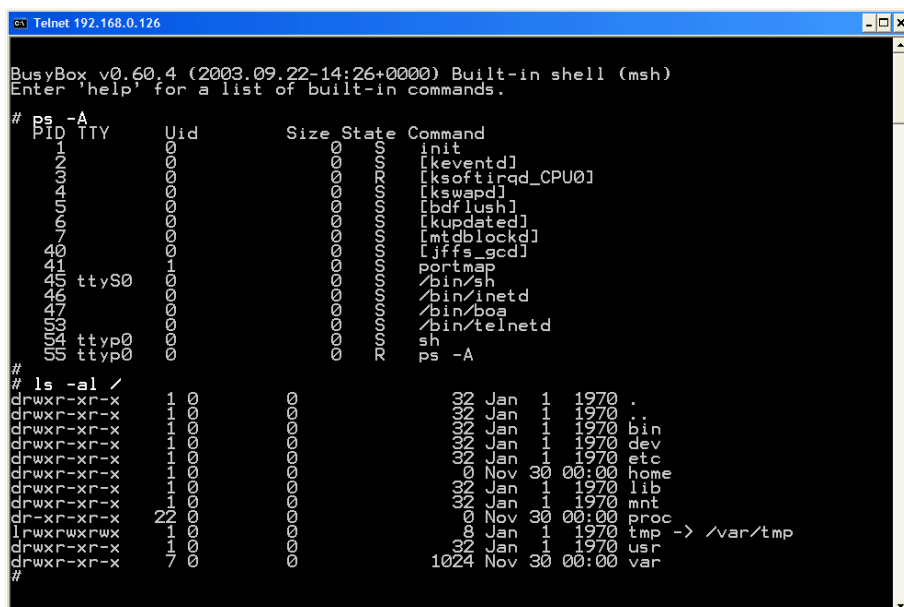

**Figure 13:** Using  $\mu$ Clinux commands within a Telnet client window

## Helpful Literature

---

ColdFire Programmers Reference Manual R.1.0 (MCF5200PRM/AD)  
MCF5282 ColdFire Microcontroller User's Manual R.0.1 (MCF5282UM/D)  
Motorola dBUG Reference Manual Revision 0.21

## Contact

---

SSV Embedded Systems  
Heisterbergallee 72  
D-30453 Hannover  
Tel. +49-(0)511-40000-0  
Fax. +49-(0)511-40000-40  
E-Mail: sales@ist1.de  
Web: www.ssv-embedded.de  
Web: www.dilnetpc.com

## Notes to this Document (PNP5280-SK20\_FS EA1.doc)

---

Revision	Date		Name
1.00	17.05.2005	First Version in English (Rev. 1.00)	KDW

© SSV Software Systems GmbH and Klaus-Dieter Walter 1999 – 2005. All rights reserved. No part of this documentation may be copied or reproduced in any form or by any means without the prior written consent of SSV Software Systems GmbH and Klaus-Dieter Walter. Trademarks, brands, or names included in this documentation are for identification purposes only and may be the property of others.

SSV Software Systems GmbH makes no warranty for the use of its products and assumes no responsibility for any errors which may appear in this documents nor does it make a commitment to update the information contained herein. SSV Software Systems GmbH retains the right to make changes to these specifications at any time, without notice. Contact the SSV Software Systems GmbH sales office to obtain the latest specifications before placing your order.